



Datasheet

SC5428A GREENJAY II

DC to 18 GHz RF Upconverter

www.signalcore.com

Table of Contents

1. Definition of Terms.....	3
2. Description	4
3. Block Diagram.....	5
4. Frequency Specifications.....	6
5. Amplitude Specifications.....	7
6. Spectral Specifications.....	9
7. Dynamic Range Specifications	11
8. General Specifications	12
9. Revision Table.....	14

1. Definition of Terms

The following terms are used throughout this datasheet to define specific conditions:

Specification (spec)	Defines expected statistical performance within specified parameters which account for measurement uncertainties and changes in performance due to environmental conditions. Protected by warranty.
Typical Data (typ)	Defines the expected performance of an average unit without specified parameters. Not protected by warranty.
Nominal Values (nom)	Defines the average performance of a representative value for a given parameter. Not protected by warranty.
Measured Values (meas.)	Defines the expected product performance from the measured results of an individual sample or a batch of samples.

Specifications are subject to change without notice. For the most recent product specifications, visit www.signalcore.com.

2. Description

The SC5428A, a member of the GREENJAY family of modular super-heterodyne frequency converters, uses a three-stage up-conversion chain engineered for continuous broadband RF generation, high spectral purity, and excellent image suppression. It accepts either a high-IF input from approximately 1.5 GHz to 3.25 GHz or a baseband I/Q input from DC to 500 MHz, with a dedicated low-frequency path that routes DC – 3 GHz content directly into final output stage. This architecture enables both wideband IF-to-RF bypass operation and high-performance frequency translation within a single compact module.

The upconverter provides –30 dB to +35 dB of adjustable gain through integrated attenuators, with the I/Q conversion path supporting -40 dB to +20 dB of adjustable gain. Depending on system requirements, the SC5428A can operate as a high-IF upconverter, a low-IF/baseband I/Q modulator, or a wideband IF-to-RF bypass element. The RF output covers ~DC to 18 GHz, with the full three-stage conversion chain supporting 1.5 GHz to 18 GHz and the bypass path supporting DC – 3 GHz translation.

All LO signals are externally supplied to support coherent multi-channel architectures, with two LO sources required for operation through the second IF stage and three LO sources for full up-conversion from DC – 500 MHz I/Q to RF. External LO injection ensures deterministic phase alignment across multiple modules, enabling coherent receivers, phased arrays, and precision measurement systems.

The compact size of the SC5428A makes it well suited for dense system integration, particularly in multi-channel platforms or designs with limited real estate. Its broadband capability, configurable IF structure, large gain adjustment, and coherent LO architecture make it applicable to advanced communication transmitters, automotive radar and coherent receiver systems.

3. Block Diagram

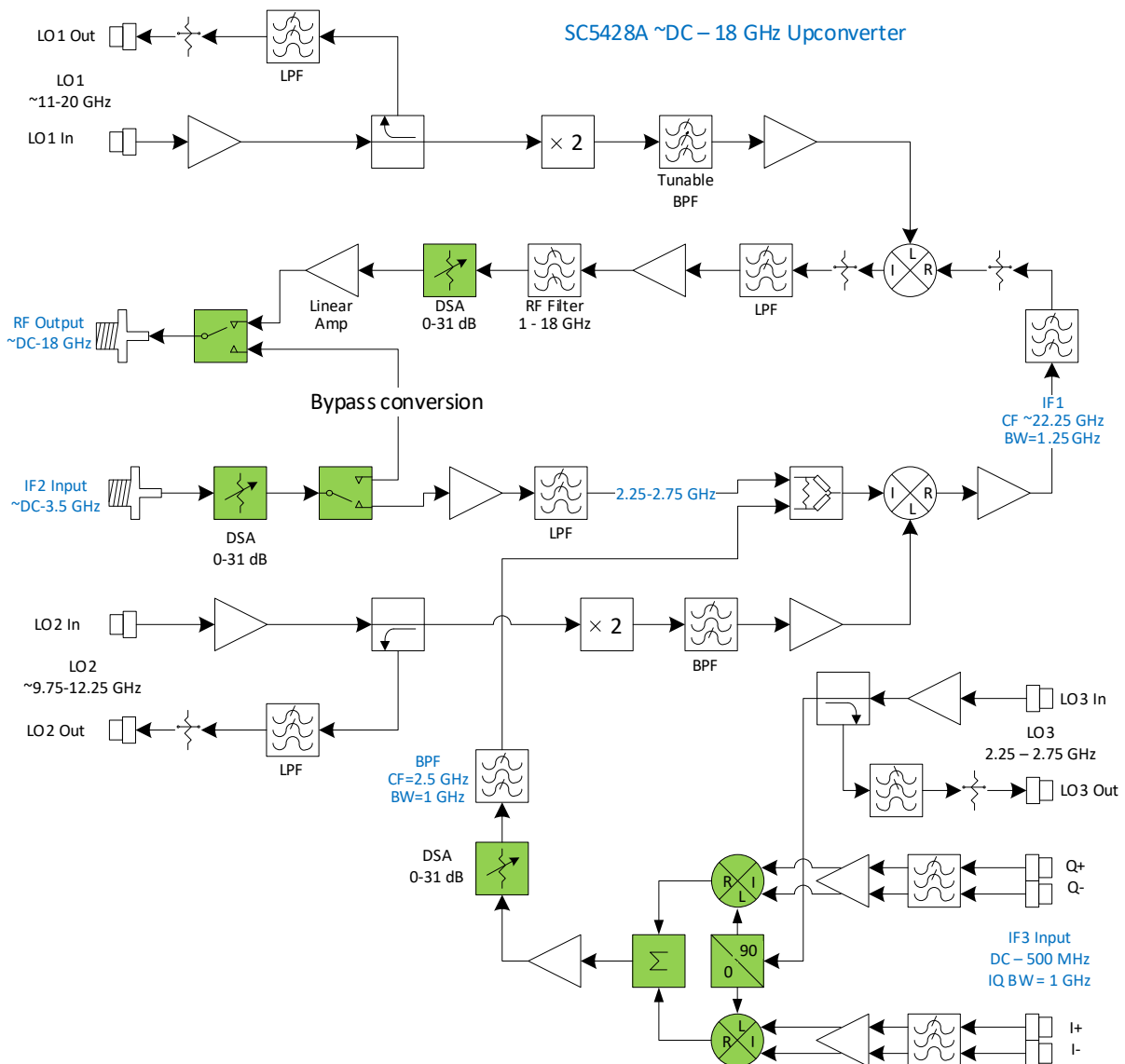

Figure 1 Upconverter block diagram. Green blocks present user adjustability

4. Frequency Specifications

Frequency Specifications

RF Output Range

RF	Bypass	DC to 3.5 GHz
	Conversion	1.5 GHz to 18.0 GHz

IF Input Range

IF2	Bypass	DC to 3.5 GHz
	Conversion	1.5 GHz to 3.25 GHz
IF3/IQ		DC to 500 MHz

IF Bandwidth

IF2		1.25 GHz
-----	--	----------

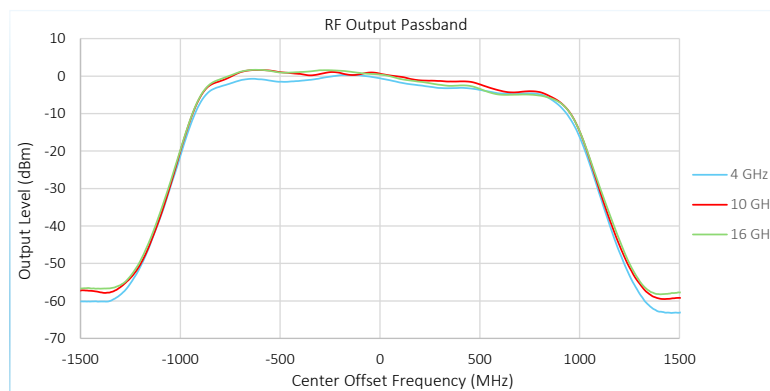

Figure 2 RF output bandwidth from IF2 input

IF3/IQ ¹		1000 MHz
---------------------	--	----------

RF Output Polarity

IF2		Non-inverted/Inverted
IF3/IQ		Non-inverted/Inverted

LO Range²

LO1		11 GHz to 20.5 GHz, typ
LO2		9.75 GHz to 12.25 GHz, typ
LO3		DC to 3.5 GHz, typ

Port VSWR

RF Port VSWR		TBD
IF2 Port VSWR		TBD
IF3 Port VSWR		TBD

¹ Analog bandwidth = 500 MHz, I/Q bandwidth is 1 GHz

² Required LO frequency range for full conversion range

5. Amplitude Specifications

Amplitude Specifications

Conversion Gain³

IF2 to RF ⁴	1.5 GHz to 6 GHz	+36 dB, typ
	6 GHz to 15 GHz	+31 dB, typ
	15 GHz to 18 GHz	+27 dB, typ

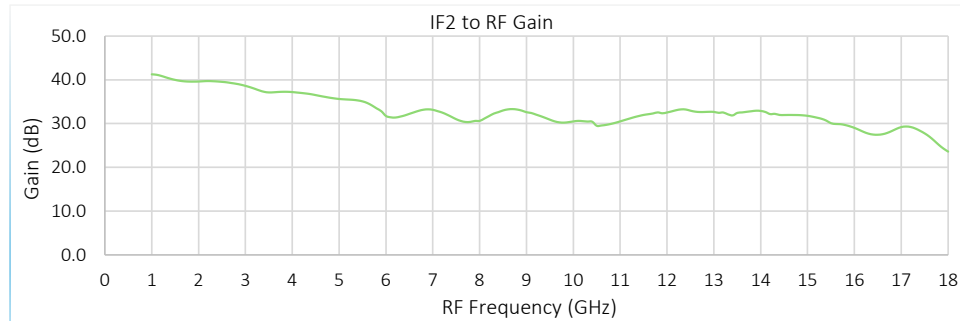

Figure 3 Conversion gain, IF2 = 2.5 GHz

IF3 to RF ⁵	RF: 1.5 GHz to 6 GHz	+18 dB, typ
	RF: 6 GHz to 15 GHz	+14 dB, typ
	RF: 15 GHz to 18 GHz	+9 dB, typ

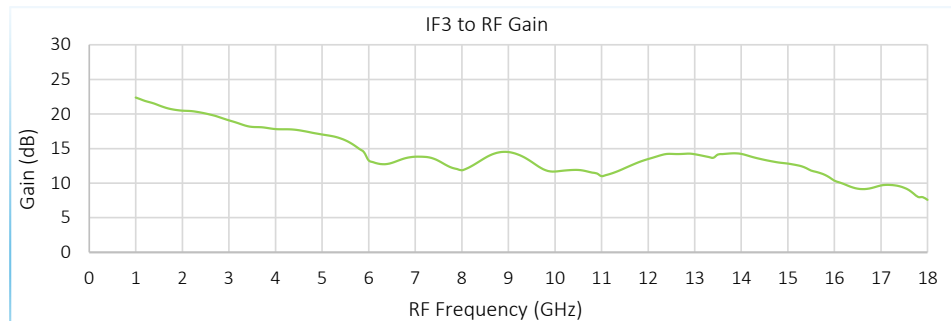

Figure 4 Conversion gain, IF3 = 250 MHz

Bypass Conversion Gain⁶

IF2 to RF	500 MHz	+9 dB, typ
	1.5 GHz	+8 dB, typ
	2.5 GHz	+7 dB, typ

³ IF2 = 2.5 GHz and IF3 = 250 MHz

⁴ 0 dB RF attenuation, 0 dB IF2 attenuation

⁵ 0 dB RF attenuation, 0 dB IF3/IQ attenuation

⁶ 0 dB RF attenuation

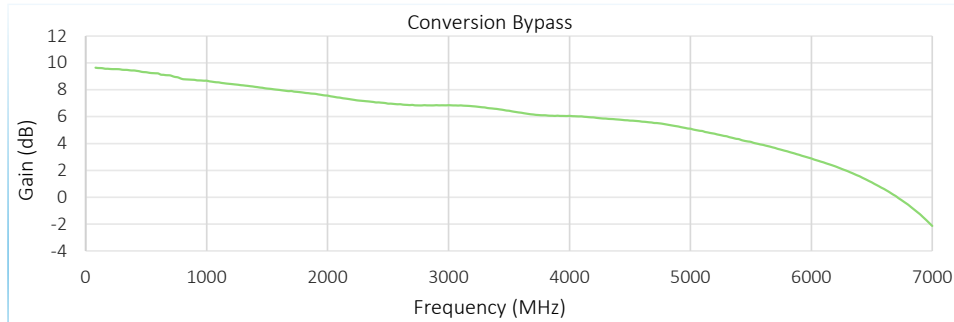

Figure 5 Pass-through gain, 0 dB Attenuation

Gain Adjustment

RF Attenuation	0.5 dB steps	0 dB to 31.5 dB
IF2 Attenuation	0.25 dB steps	0 dB to 31.75 dB
IF3/IQ Attenuation	0.25 dB steps	0 dB to 31.75 dB

RF Gain Flatness

IF2 to RF	1.5 GHz to 18 GHz	17 dB, typ
IF3 to RF	1.5 GHz to 18 GHz	16 dB, typ
Over 1 GHz bandwidth		3 dB, typ

IF2 Input Level

Absolute	+20 dBm, max
----------	--------------

IF3/IQ Level

VCOM	0 V - 0.5 V, typ
Differential	1.3 Vpp, max

LO Drive Level

LO1, LO2, LO3	+7 dBm, max	+4 dBm, typ
---------------	-------------	-------------

LO Output Gain

LO1	+2 dB, typ
LO2	+4 dB, typ
LO3	+4 dB, typ

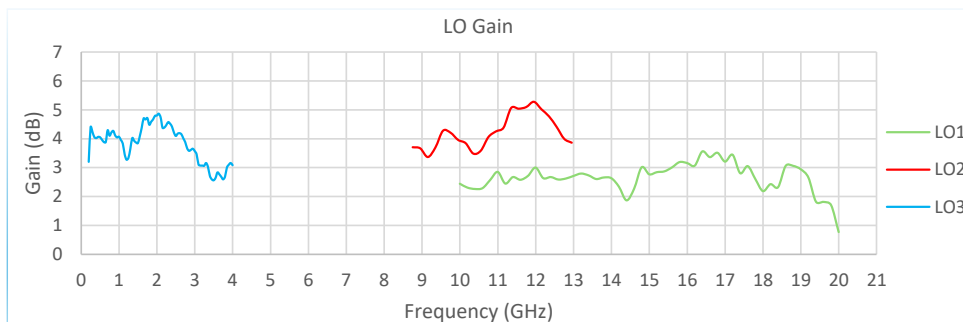

Figure 6 LO input to output gain

6. Spectral Specifications

Spectral Specifications

IF Isolation

IF2 to RF⁷

<-95 dBc, typ

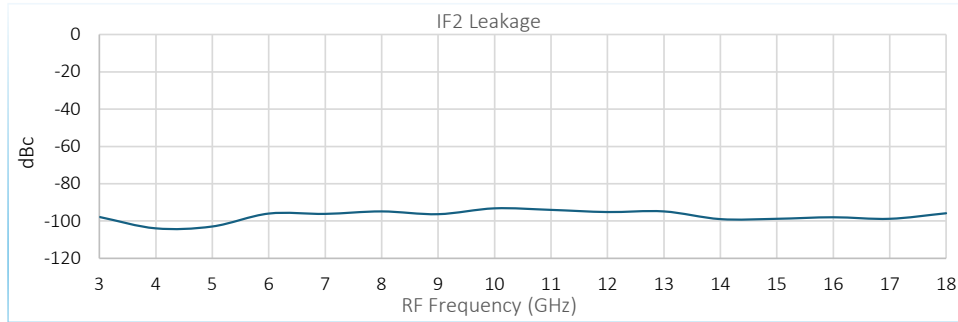

Figure 7 IF2 Leakage at RF output

IF3 to RF⁸ LO Leakage at RF⁷

3 GHz to 18 GHz

<-90 dBc, typ

	max	typ
LO1	<-55 dBc	<-65 dBc
LO1 x 2	<-55 dBc	<-65 dBc
LO2	<-80 dBc	<-90 dBc
LO2 x 2	<-70 dBc	<-80 dBc

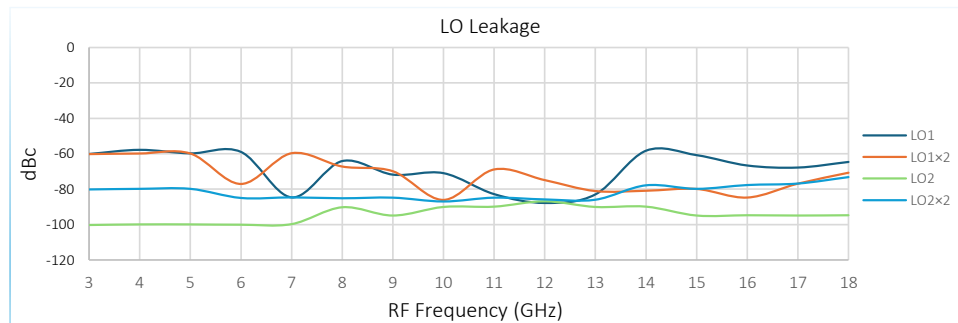

Figure 8 LO leakage at RF output

⁷ -20 dBm 2.5 GHz IF2 input; 0 dBm RF output

⁸ 250 MHz IF3, +5 dB gain

LO Leakage at IF2⁹

+4 dBm LO input drive

LO1	<-85 dBc, typ
LO1 x 2	<-85 dBc, typ
LO2	<-77 dBc, typ
LO2 x 2	<-77 dBc, typ

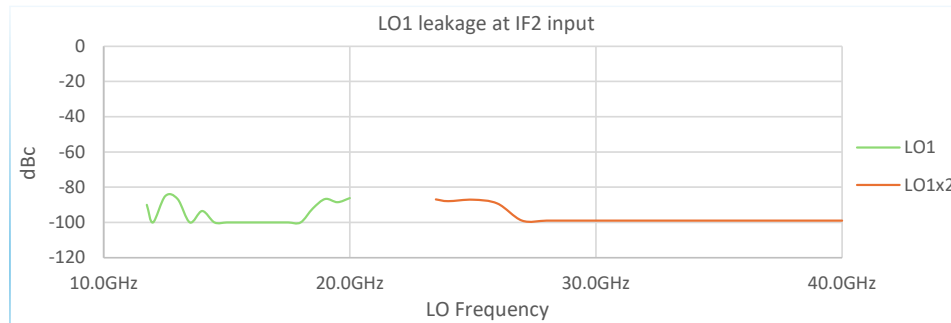

Figure 9 LO1 leakage at IF2 input

Spurious Signals¹⁰

LO1xLO2 Intermodulation	Out-band	<-75 dBm	<-80 dBm
Higher LO order intermodulation	Out-band	<-60 dBm	<-65 dBm
RF induced spurs			
RF Frequency: 3 GHz to 18 GHz	In-band		<-70 dBc, typ
1.9 GHz to 3.1 GHz ¹¹	In-band		<-60 dBc, typ
6.9 GHz to 7.7 GHz ¹²	In-band		<-50 dBc, typ

2nd Harmonics (0 dBm)

1.5 GHz to 7 GHz	<-30 dBc, max	<-45 dBc, typ
7 GHz to 11 GHz	<-40 dBc, max	<-45 dBc, typ
11 GHz to 15 GHz	<-35 dBc, max	<-45 dBc, typ
15 GHz to 18 GHz	<-45 dBc, max	<-55 dBc, typ

3rd Harmonics (0 dBm)

1.5 GHz to 7 GHz	<-60 dBc, max	<-70 dBc, typ
7 GHz to 11 GHz	<-70 dBc, max	<-75 dBc, typ
11 GHz to 16.5 GHz	<-75 dBc, max	<-80 dBc, typ

⁹ 0 dB attenuation, measured with respect to LO power¹⁰ -20 dBm 2.5 GHz IF2 input; 0 dBm RF output¹¹ RF – IF2¹² IF1 – LO1

Spectral Specifications

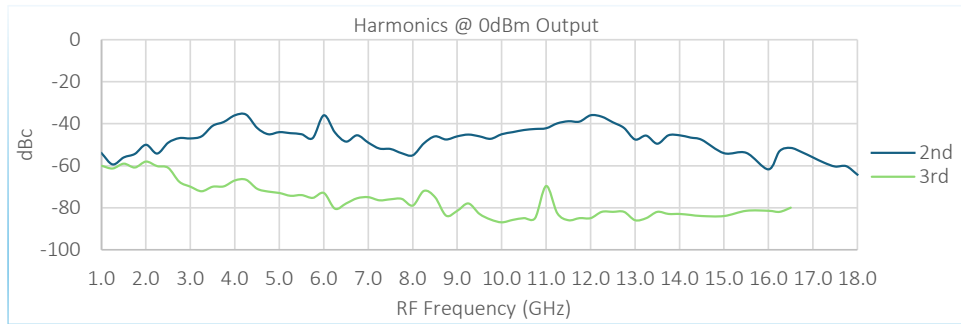

Figure 10 RF harmonic levels at 0 dBm output level

7. Dynamic Range Specifications

Dynamic Range Specifications

Noise Figure	25 dB, typ
Output Noise Density ¹³	-128 dBm/Hz, typ
Spurious Free Dynamic Range	102 dB
Output third-order intermodulation OIP3 ¹⁴	+27 dBm, typ

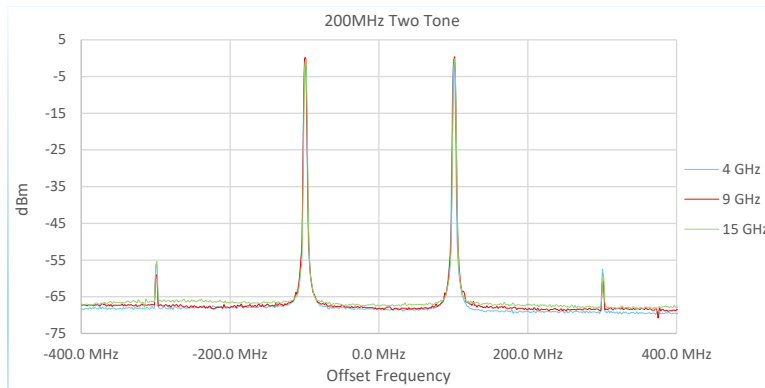

Figure 11 IMD performance, -20 dBm 2.5 GHz IF2 input, +20 dB gain

Output compression OP1dB	+10 dBm to +25 dBm
--------------------------	--------------------

¹³ 0 dBm output

¹⁴ OIP3 measured with 2.5 GHz IF2, -20 dBm two-tone input (200 MHz spacing), 0 dBm output

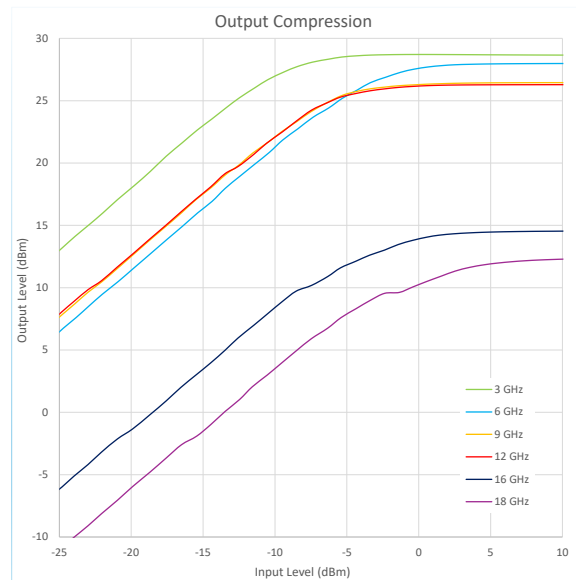

Figure 12 Output compression

8. General Specifications

General Specifications

Environmental

Internal Device Operating Temperature ¹⁵	-10°C to +70°C
Ambient Storage Temperature	-40°C to +90°C
Operating Relative Humidity	10% to 90%, non-condensing
Storage Relative Humidity	5% to 90%, non-condensing
Operating Shock	30 g, half-sine pulse, 11 ms duration
Storage Shock	50 g, half-sine pulse, 11 ms duration
Operating Vibration	5 Hz to 500 Hz, 0.31 g _{rms}
Storage Vibration	5 Hz to 500 Hz, 2.46 g _{rms}
Altitude	Up to 33,000 feet (de-rate max device temperature to 60°C)

Physical¹⁶

Dimensions (W x H x D, max envelope)	3.7" x 0.75" x 6.00"
Weight	1.0 lb.
RF Output Connector	K-type, 2.92 mm
IF2 Input Connector	K-type, 2.92 mm
Connector Nominal Impedance	50 Ω
IF3/IQ Connectors	MMCX, female
LO Input and Output Connectors	SMPM, female

¹⁵ Per read back from internal temperature sensor.

¹⁶ See 3D and 2D mechanical files for more information on precise module dimensions and mounting hole positions.

		General Specifications
Digital Interface Connector ¹⁷		M80-5401442
Communication Interface		USB, UART and SPI
UART, SPI and I/O Logic		3.3V LVCMOS, 5V Tolerant
Supply Connector		1.7mmx4.0mm Male Jack
Input Voltage		10 to 15 VDC
		5V, 12V
Current	Peak (initial)	2.4 A max @ 12V
	Steady (typical)	2.1 A @ 12V
Power Consumption	Steady	24 W max

Electromagnetic Compatibility (EMC)

This product meets the requirements of the following EMC standards for electrical equipment for measurement, control, and laboratory use:

- EN 61326-1 (IEC 61326-1): Basic immunity
- EN 55011 (CISPR 11): Class A Radiated emissions
- EN 55011 (CISPR 11): Class A Conducted emissions
- EN 61000-4-2: Electrostatic Discharge
- EN 61000-4-3: Radiated Immunity
- EN 61000-4-6: Conducted Immunity
- FCC 15.109: Radiated emissions
- ICES-003: Class A emissions

CE

This product meets the essential requirements of applicable European Directive:

- 2014/30/EU; Electromagnetic Compatibility Directive (EMC)

Warranty

3 years on parts and labor on defects in materials or workmanship.

¹⁷ See hardware manual for more information on connectors and their pinouts.

9. Revision Table

Revision	Revision Date	Description
0.1.0	05/27/2026	Preliminary

